



AEROBAR TWO 2025
SELECTION AND GENERAL ASSEMBLY GUIDELINES

INTRODUCTION

We're pleased to welcome you to a global family of athletes embracing more comfortable, more effective time trial positions. Sync Ergonomics strongly recommends the installation of your Sync components to be undertaken by a qualified bicycle mechanic, experienced with time trial and triathlon bicycles. Irrespective of your level of mechanical experience, please read the following guide as it contains information vital for correct setup and use.

This document has been prepared to guide you through the assembly of your AB02 ecosystem. Care must be taken during the installation process to ensure proper function and ongoing maintenance must be performed to ensure longevity of your Sync Ergonomics components.

WARNING: In order to be installed correctly the components of Aerobar Two (AB02) require specialised knowledge of a time trial bicycle. It is recommended that installation should be performed by a qualified bicycle mechanic. Improper assembly of any of the components of AB02 could cause damage to the product(s) and/or bicycle, may lead to loss of control of the bicycle, and may lead to personal injury, or in severe cases even death. Sync Ergonomics assumes no responsibility for improper assembly and installation of the product(s).

WARNING: Please have your bicycle and Sync Ergonomics products regularly inspected for possible damage from use, especially from instances such as accidents, crashes, and/or impact that occurs with travel. In the event of an accident, crash and/or impact in travel, it is strongly recommended you stop using your bicycle immediately and take your bicycle to a professional bicycle mechanic for inspection to ensure proper function and safety. In the case of damage, replace affected parts immediately. Even when no damage is visible, there may be internal damage to the integrity of a component. Failure to replace damaged parts could result in loss of control, and may lead to personal injury, or in severe cases even death. Sync Ergonomics assumes no responsibility for improper maintenance and inspection of the product(s).

WARRANTY

Sync Ergonomics components are free from material and manufacturing defects for a period of 12 months starting from the original purchase date, unless otherwise stated in our warranty policy, detailed on our website at www.syncergonomics.com. This warranty is non-transferable and only applicable to the original customer who purchased this product and this product only. Any modifications to the product, other than for its original intended use, such as drilling, will effectively and immediately void the warranty.

For more information on our warranty policy and instructions for completing a warranty claim, please visit our website for full details at www.syncergonomics.com.

REQUIRED TOOLS AND PRODUCTS

Torque wrench (with Hex and Torx drivers)
4 mm T-Handle Hex key
T10 and T25 Torx keys
Cutting guide (Park Tool SG-6)
Hack saw and a high-quality 32 TPI blade
Fine metal file or deburring tool
Isopropyl alcohol
MOTOREX Bike Grease
222 Loctite
Assembly paste (carbon paste) – If using carbon extensions

WARNING: Your bike may require additional tools to what is mentioned above and we cannot guarantee that these recommendations will cover the requirements of all bikes. If in doubt, ensure assembly is handled by a qualified bicycle mechanic, experienced with the assembly and setup of a time trial bicycle.

WARNING: Do not attempt to modify your Sync components, outside of what is described within this setup guide as appropriate for assembly. Modification may impact the structural integrity of the components and could result in component failure, or failure of the complete system. Sync Ergonomics is not liable for product damage and/or personal injury resulting from improper assembly.

BIKE-SPECIFIC COMPATIBILITY

AB02 and AB03 aerobars are compatible with bike-specific basebars only. Attempting to install an AB02/AB03 ecosystem on any basebar (or bike) other than intended would require modifications that would likely lead to issues with structural integrity and will immediately void the product warranty.

For more information and technical resources, please visit <https://www.syncergonomics.com/technical>.

INTRODUCTION

The AeroBar Two (AB02) ecosystem is an integrated, modular solution designed to facilitate better positioning and aerodynamics on a time trial bike. The AB02 system provides dedicated arm cup angulation (15-degrees) and a more forward arm cup position. There are two categories of AB02 systems – Centre Stack and Dual Stack.

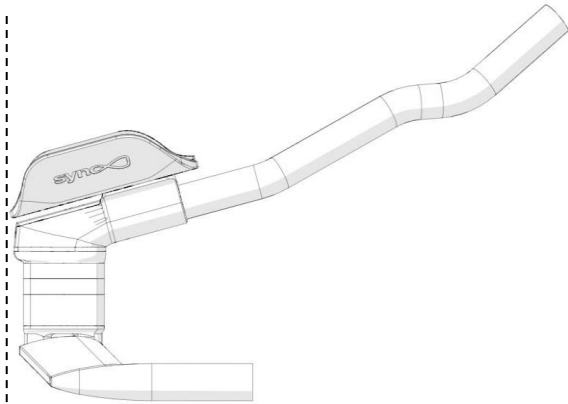

SUITABILITY

It is important to note some key geometry differences between AB02 and your OEM bike components.

In the most rearward position, the back edge of the arm cup sits flush with the rear of the extension clamp. On most bikes, this falls roughly in line with the back edge of the base bar.

If you require your arm cups to be positioned further back on the spacer stack, the AB02 ecosystem may not be suitable for your time trial position.

GROUPSET COMPATIBILITY

The AB02 ecosystem is only compatible with Shimano Di2 (SW-R9160), SRAM eTap Clics and SRAM AXS wireless blips (using our TT grips).

EXTENSION SELECTION – FOREARM MEASUREMENT

Two AB02 extension options are available, **MEDIUM** and **LONG**. The difference in length between the two options is 40 mm, with this additional length being added in the mid-section of the Long extensions. The overall height, the clamp end geometry and the grip end geometry are consistent between both the Medium and the Long extensions.

Most bikes and positions requiring UCI compliance will require the Medium extensions.

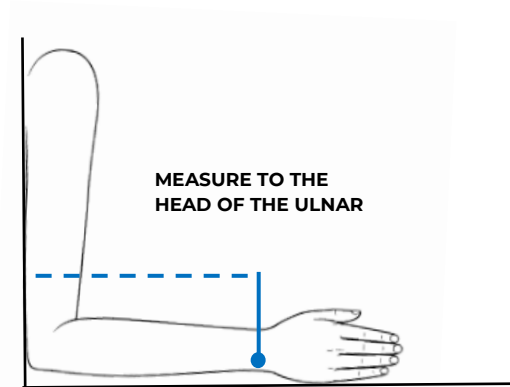

FOREARM MEASUREMENT	UCI CATEGORY	EXTENSION
SHORTER THAN 280 MM	CATEGORY 1 OR 2	MEDIUM
LONGER THAN 280 MM	CATEGORY 3	LONG

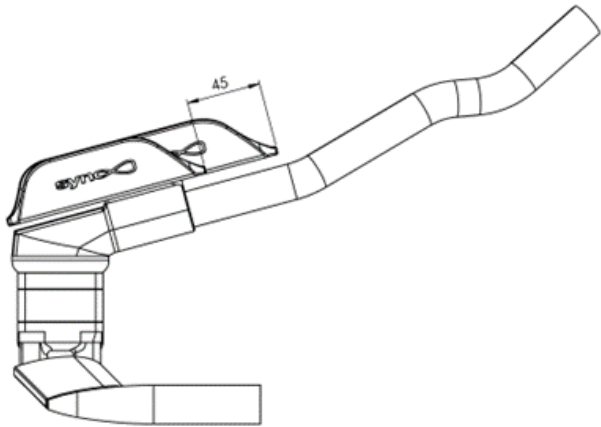

LENGTH ADJUSTEMENTS

The length adjustment range for our Base arm cups is 45 mm, in 15 mm increment.

WIDTH ADJUSTEMENT

AB02 ecosystems have been configured around an extension clamp spacing of 125 mm (center-to-center).

A total of 46 mm of lateral arm cup adjustment is available with our Base arm cups.

Maximum width is 242 mm
Minimum width is 196 mm

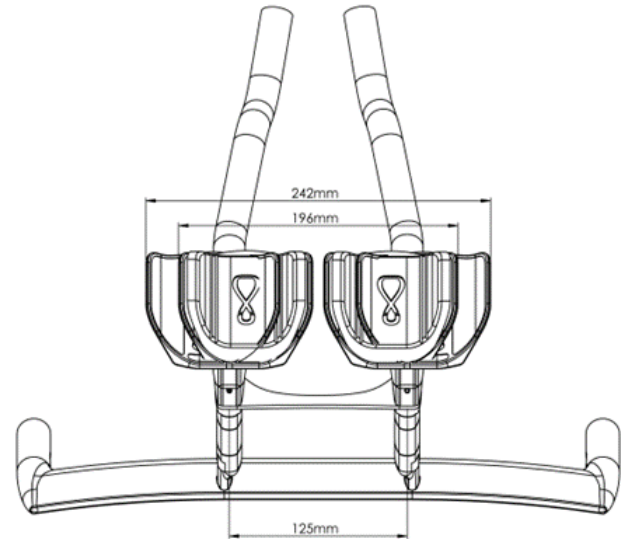

STACK ADJUSTEMENT

AB02 2025 Dual Stack systems come with 30 mm of spacers as standard. With basebar adapters, spacers, extension clamps and arm cup installed, this will typically result in about 90 mm stack height, to the surface of the arm cup (basebar adapter dependant).

Spacer Kit B can be purchased which provides an additional 30 mm of spacers and allows most Dual Stack systems to be configured at 120 mm of height, from the surface of the basebar.

The AB02 ecosystem allows for adjustment of pad stack in 10 mm increments.

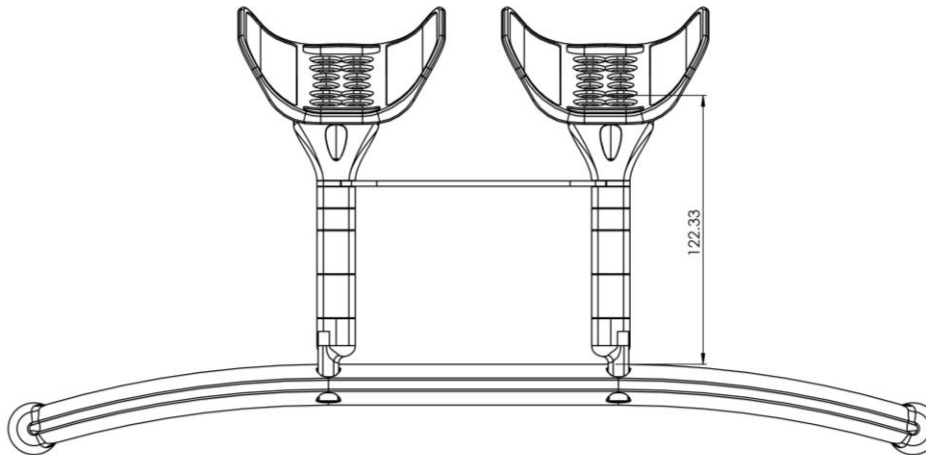

DUAL STACK SOLUTIONS

Sync offers a range of Dual Stack fit kits, that share the following common design characteristics.

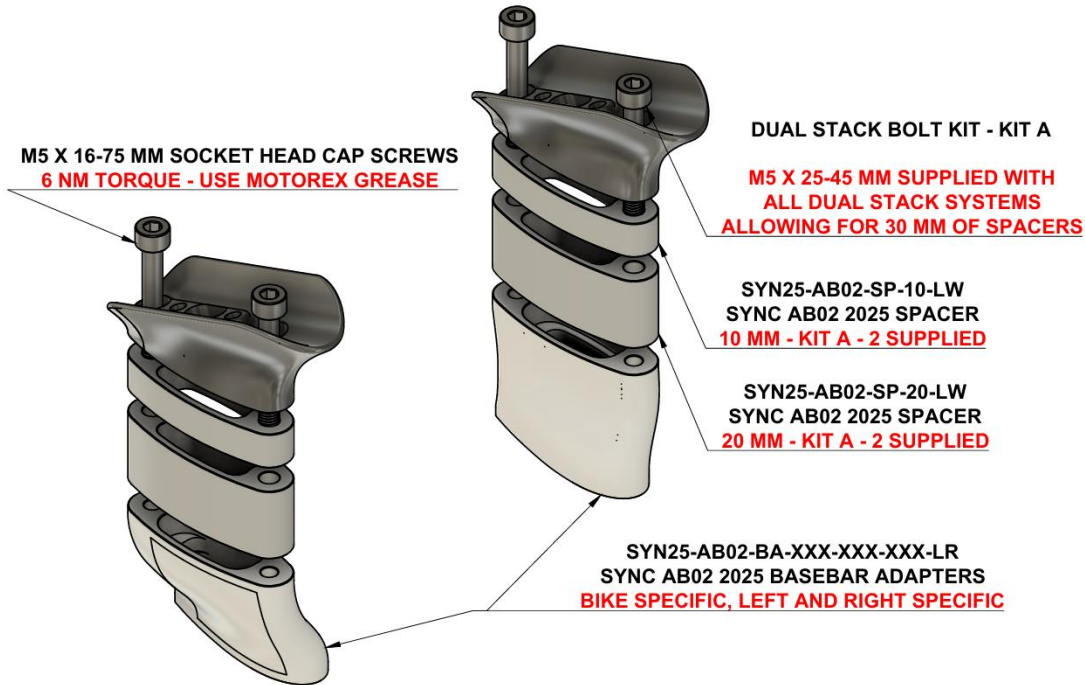

Note: *Spacer Kit B (+30 mm) is available during checkout and includes Bolt Kit B (for up to 60 mm spacer height).*

For more information and technical resources, please visit <https://www.syncergonomics.com/technical>.

CENTRE STACK SOLUTIONS

Sync offers a range of Centre Stack fit kits, that share the following common design characteristics.

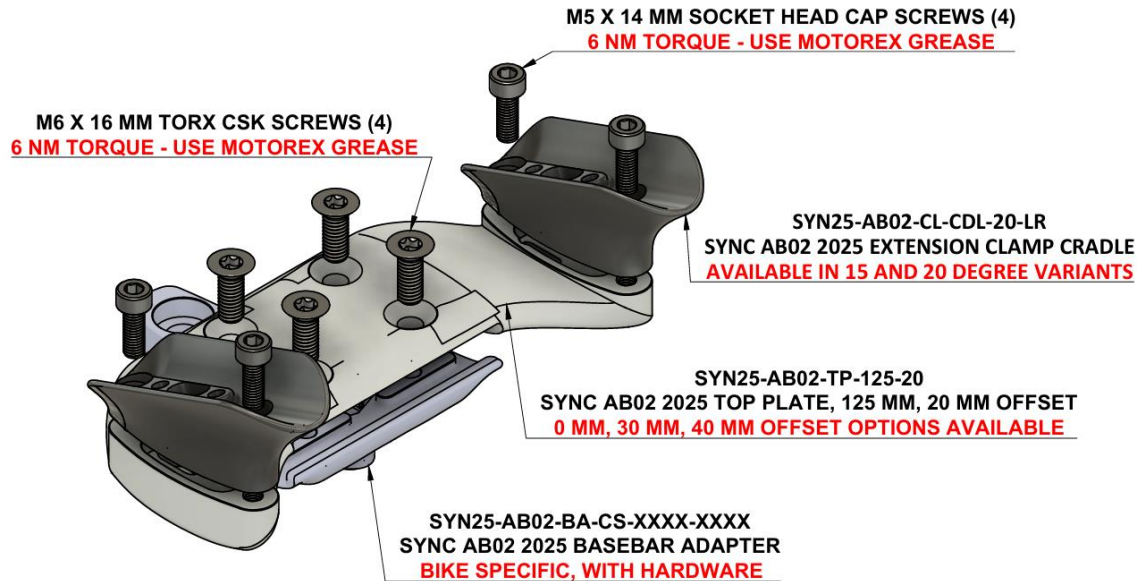

Note: Centre Stack solutions use the bikes original spacer stack for adjustment to stack height. We do not supply stack spacers for AB02/AB03 Centre Stack Solutions.

For more information and technical resources, please visit <https://www.syncergonomics.com/technical>.

DUAL STACK SOLUTIONS – BRIDGE

Above 30 mm of spacers, we recommend that a support brace (bridge) is used with all Dual Stack solutions. All bikes, with the exception of the Colnago TT1 use our 125 mm (C-C) spacing for extensions.

The Colnago TT1 is spaced at 115 mm (C-C) and requires the Colnago TT1 UCI bridge. UCI Bridges are 10 mm thick and take the place of a single 10 mm spacer.

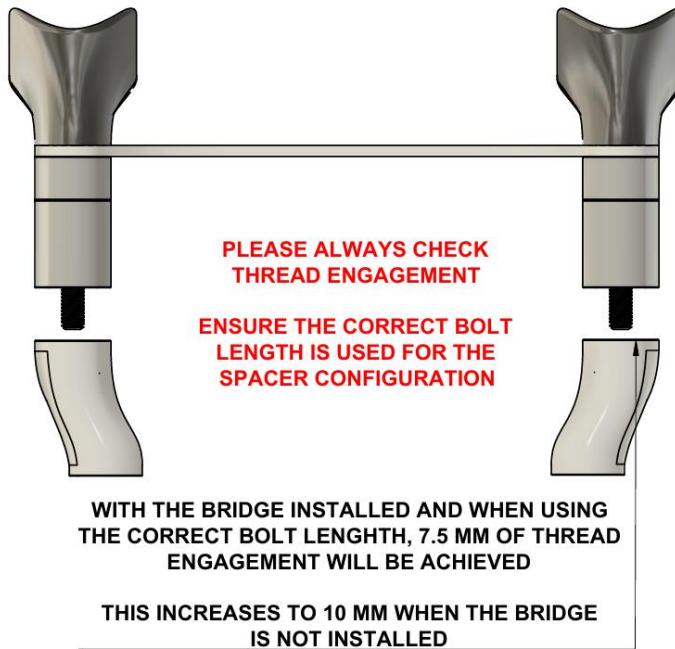

DUAL STACK SOLUTIONS – SPACER KIT

AB02/AB03 Dual Stack fit kits are supplied with 30 mm of spacers and Bolt Kit A. This includes M5 x 25-45 mm bolts, which cater for 10-30 mm of spacers being installed.

Bolt Kit B and Spacer Kit B are available to purchase during checkout and include an additional 30 mm of spacers and M5 x 55-75 mm bolts, covering up to 60 mm of spacers.

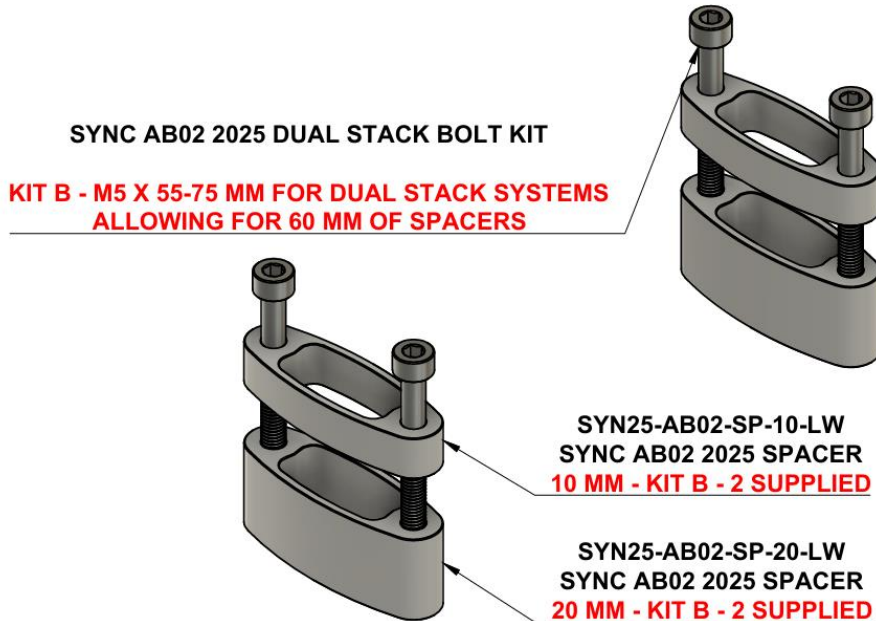

EXTENSION CLAMP AND CRADLE

The extension clamp and extension clamp cradle are components that apply to all Centre Stack and Dual Stack 2025 Aerobar Two ecosystems. Please see the following for assembly noting bolt torque and the use of specific assembly compound.

Note: AB02 2025 is available with either 15 degree or 20 degree cradles.

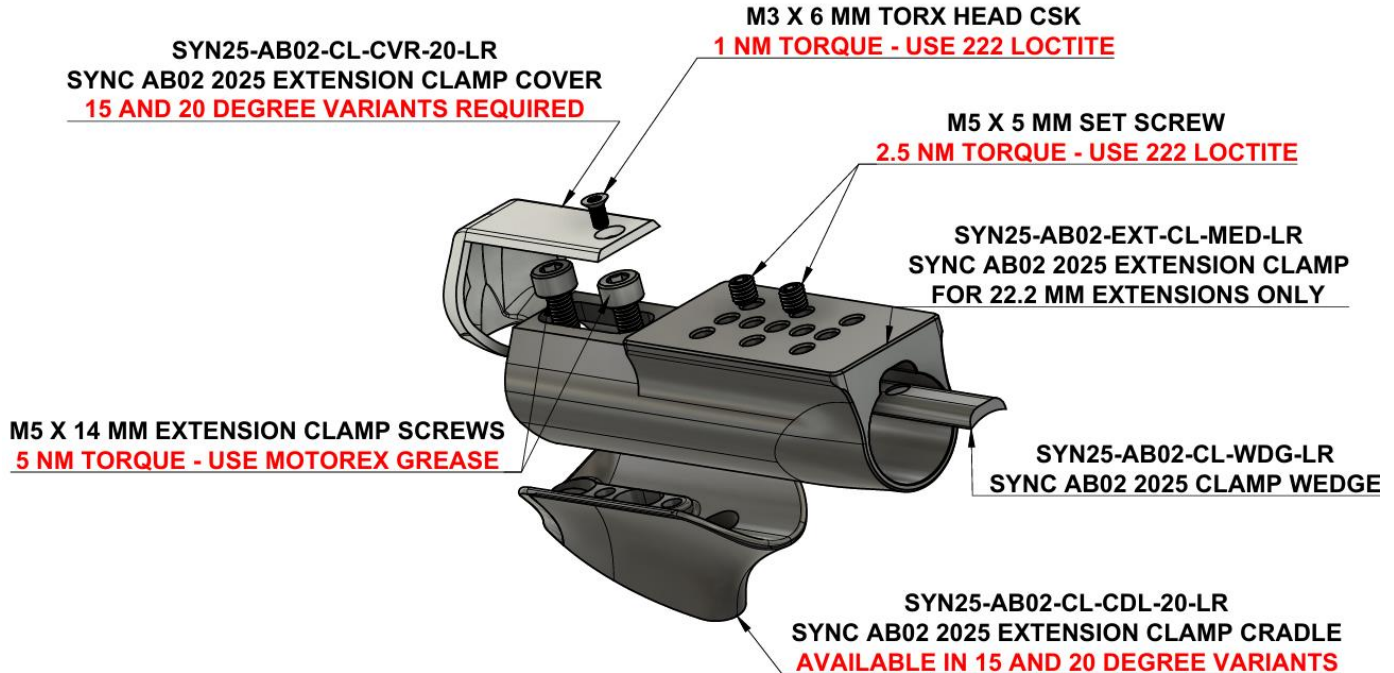

EXTENSION ASSEMBLY

AB02 extension clamps are designed to cater for a 22.2 mm round tube. Undersized tubes may not clamp effectively and we strongly recommend you check the tolerances when using extensions other than Sync Ergonomics extensions.

Note: When installing carbon tubes, we recommend the use of a fine-grit assembly paste or carbon paste.



NOTES ON WIRING

SHIMANO DI2 Thanks to the connection at the shifter, you can run the Di2 wires through the spacer stack during assembly, leaving sufficient length to connect the shifters as a final step.

The wires will run through the basebar adapter/s, through the spacers, clamp adapter and carbon brace, into the clamp and up and out of the extensions. Install your TT grips before finally affixing your shifters in place.

SRAM E-TAP Due to the nature of the wiring of SRAM CLICS, it is important that you establish the correct fit on your ABO2 setup prior to wiring the shifters. Disassembly will be required before reassembly with the SRAM wires passed through each component.

Once you have completed installation of the extensions and finished wiring the shifters, complete the clamp assembly by securing the top caps, ensuring each top cap screw is torqued to 1 Nm.

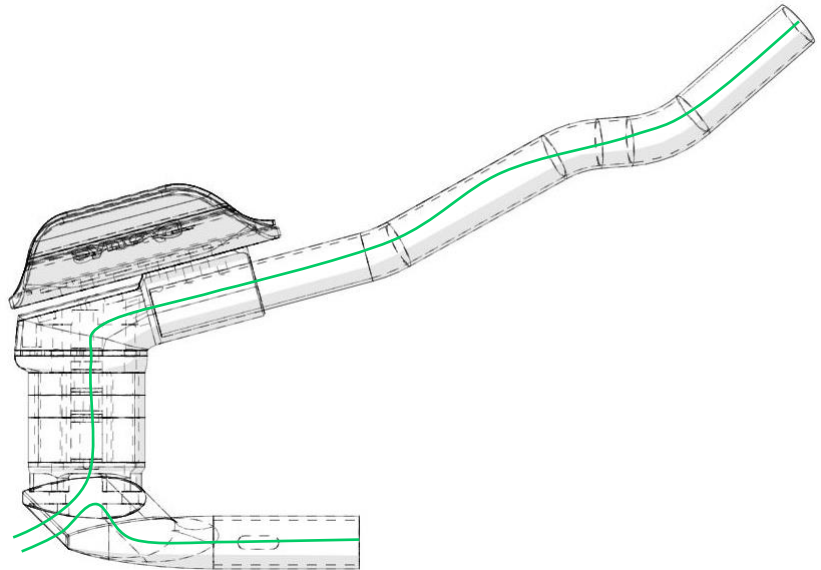

BASE ARM CUP INSTALLATION

Base arm cups are directional. Cups should be mounted with the rounded edge of the arm cup facing forward. Use the supplied M5 x 8 mm Torx flanged button head screws for connection to the extension clamp.

Note: We recommend the application of *MOTOREX Bike Grease* for the arm cup screws.

M5 X 8 MM FLANGED TORX BUTTON HEAD SCREWS
4 NM TORQUE - USE MOTOREX GREASE

