

AEROBAR TWO / THREE SETUP SUPPLEMENT

OFFSET SPACERS AND BOLT REQUIREMENTS

Available in both offset and angled offset configurations, offset spacers shift the entire extension forward on the spacer stack. Whatever the configuration, these spacers clamp down atop the spacer stack and must be clamped down using the correct bolt length, for the spacer configuration installed.

NOTE: We recommend the application of MOTOREX Bike Grease for clamp bolts.

NOTE: Clamp bolts have a suggested torque of **6 Nm**.

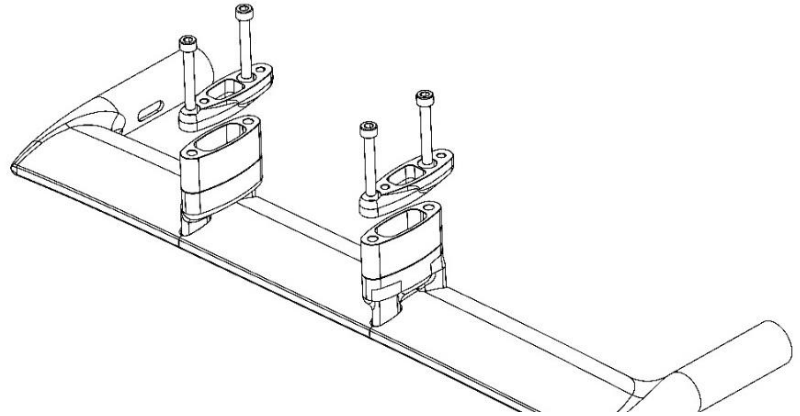

AB02 / AB03 W/OFFSET SPACER BOLT SELECTION

ESSENTIAL COMPONENTS	SPACER STACK (MM)	M5 BOLT LENGTH (MM)
BASEBAR ADAPTER + OFFSET SPACER	0	14
BASEBAR ADAPTER + OFFSET SPACER	10	25
BASEBAR ADAPTER + OFFSET SPACER	20	35
BASEBAR ADAPTER + OFFSET SPACER	30	45
BASEBAR ADAPTER + OFFSET SPACER	40	55
BASEBAR ADAPTER + OFFSET SPACER	50	65
BASEBAR ADAPTER + OFFSET SPACER	60	75

AEROBAR TWO / AEROBAR THREE EXTENSION CONNECTION - WITHOUT BRIDGE

When connecting AB02 / AB03 extensions to offset or angled offset spacers, without the use of a bridge, the extensions connect to the offset spacer using **M5 x 14 mm screws**.

NOTE: We recommend the application of MOTOREX Bike Grease for clamp bolts.

NOTE: Clamp bolts have a suggested torque of **6 Nm**.

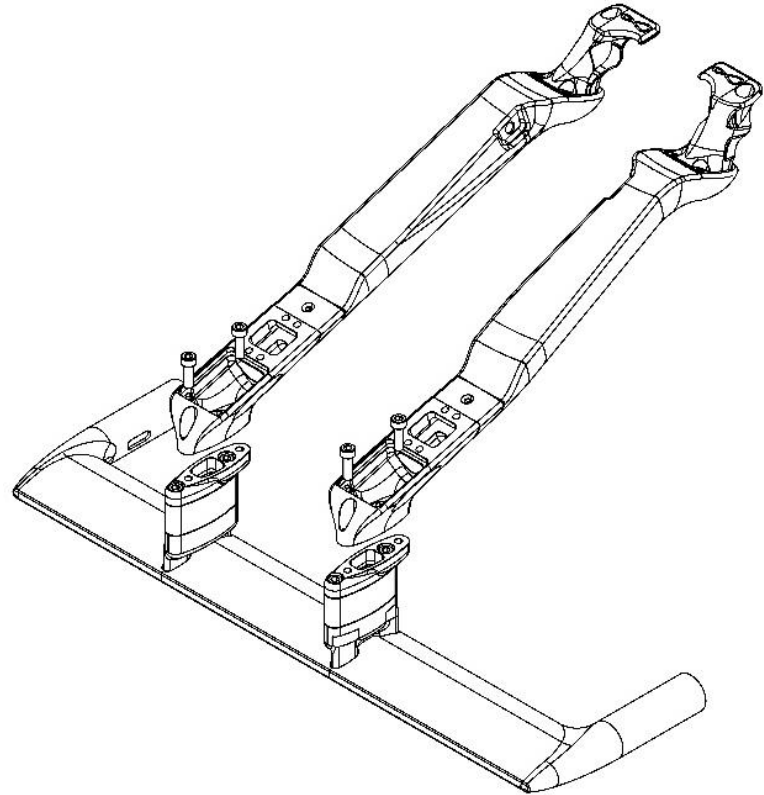

AEROBAR TWO / AEROBAR THREE EXTENSION CONNECTION - WITH 125 MM BRIDGE

The bridge sits above the angled spacer, below the AB02 / AB03 extension clamp. Please ensure the use of the correct bolt length, according to the bridge in use. We recommend the application of **MOTOREX Bike Grease** and suggest a bolt torque of **6 Nm**.

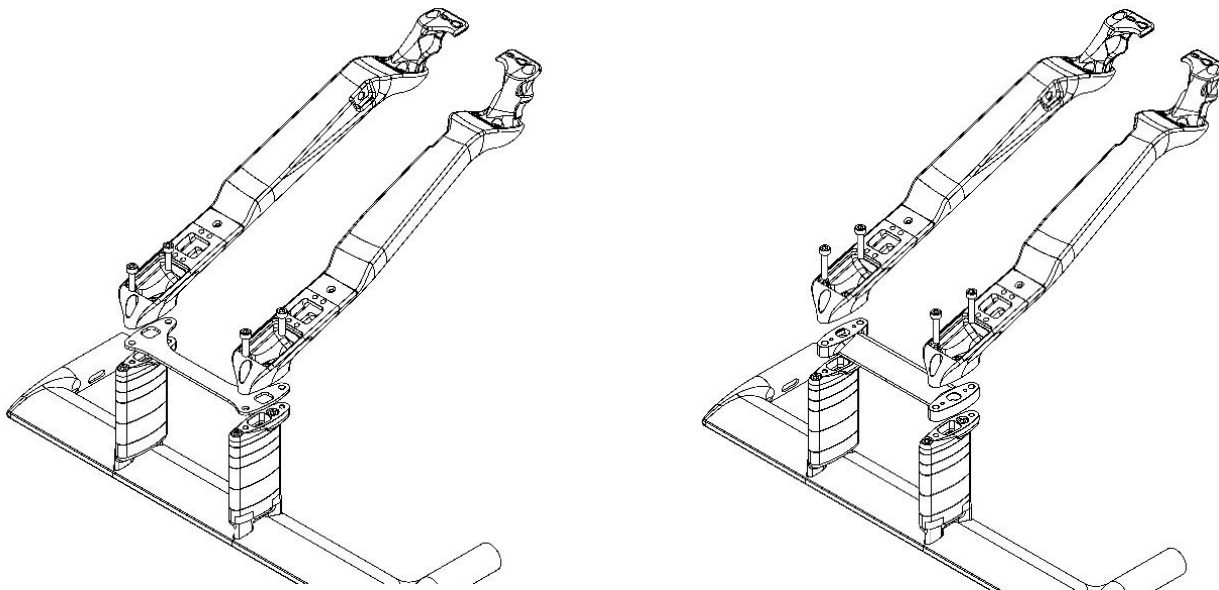

AB02 / AB03 CLAMP BOLT SELECTION - 125 MM BRIDGES

ESSENTIAL COMPONENTS	BRIDGE OPTION	M5 BOLT LENGTH (MM)
OFFSET SPACER / ANGLED OFFSET SPACER	NON-UCI - 125 MM	16
OFFSET SPACER / ANGLED OFFSET SPACER	UCI BRIDGE - 125 MM	25

AB02/AB03 EXTENSION CONNECTION – 110 AND 95 MM BRIDGE

When using our 95 or 110 mm bridge options in combination with the offset and angled offset spacers, we recommend using the bridge on top of the offset spacer. We recommend the application of **MOTOREX Bike Grease** and suggest a bolt torque of **6 Nm**.

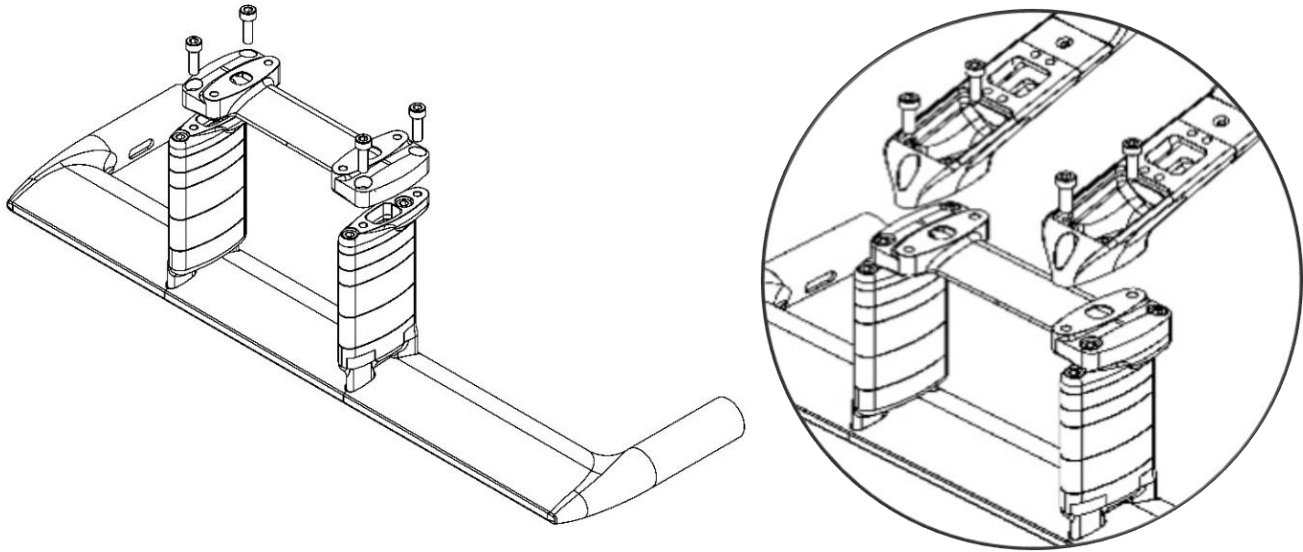

AB02/AB03 SPACER BOLT SELECTION – 95 AND 110MM BRIDGE OPTIONS

ESSENTIAL COMPONENTS	BRIDGE OPTION	M5 BOLT LENGTH (MM)
OFFSET SPACER / ANGLED OFFSET SPACER	95 MM OR 110 MM	14
AB02/AB03 EXTENSION	CONNECTION TO BRIDGE	14